



**STATS GROUP**  
Managing Pressure, Minimising Risk

**Branch Installed Self-Energised Plug - BISEP®**

**Live Double Block Isolation and Repair Services**

*Aiden Hardy – Business Development Manager*

*aiden.hardy@statsgroup.com*

*+44 (0)7469 353630*

# Dual Seal Protection Throughout All Live Operations



## Key Features

- Dual Seal Mechanical Hot Tap Fitting (If required)
- Dual Seal Slab Valve with purge facility
- Dual Seal Hot Tap Machines
- Dual Seal Isolation Equipment



*Mechanical Hot Tap Fitting*



*SureTap® ST1220-90*



*30" BISEP® & Slab Valve*

# BISEP® Features and Benefits



## Key Features

- Double Block and Bleed protection throughout the entire operation
- Fully Verifiable double block and bleed isolation through a single penetration
- No single point of failure, dual redundancy, self-energised isolation
- Available in 3" to 54" diameters - 600# as standard (900# available)
- BISEP Launcher ported to facilitate venting, purging and flushing of isolated section
- Can accommodate reinstatement pressure test through the back of the BISEP head in compliance with ASME B31.3 requirements
- Can be deployed through conventional size on size tee / clamp (welded or mechanical)
- Annular bleed port proves and monitors the seal integrity with a Zero-Energy Zone
- Hydraulic actuation allows for seal manipulation in poor pipe conditions

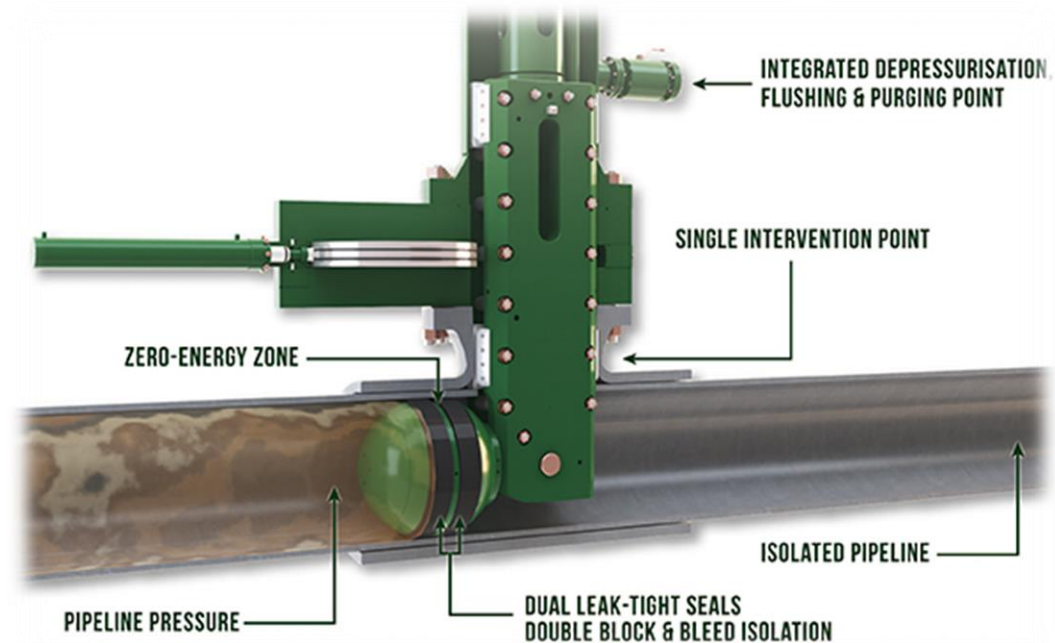

*Standard BISEP® Deployment*



# Deployment Application Methods – Continuous Production

## Standard BISEP® with Full Bore Bypass

- Production maintained during repair activities through a full bore temporary bypass
- 4 x full bore hot taps (welded or mechanical fittings)

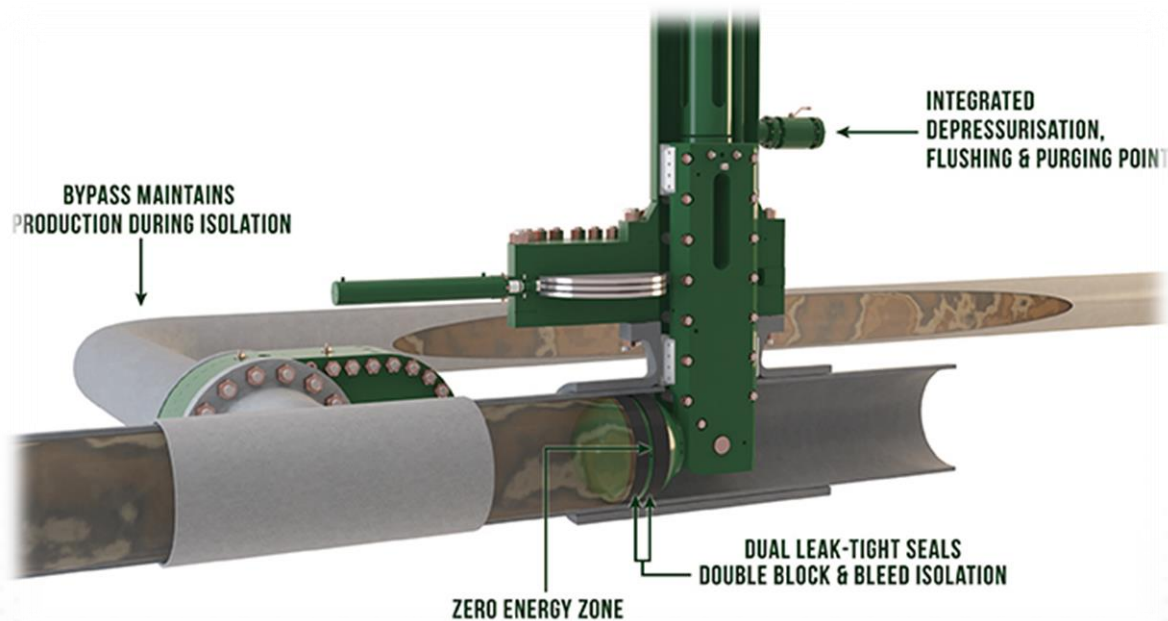

## Downstream BISEP® with Integrated Bypass

- Production maintained during repair activities through a reduced bore temporary bypass
- 2 x full bore hot taps (welded or mechanical fittings)

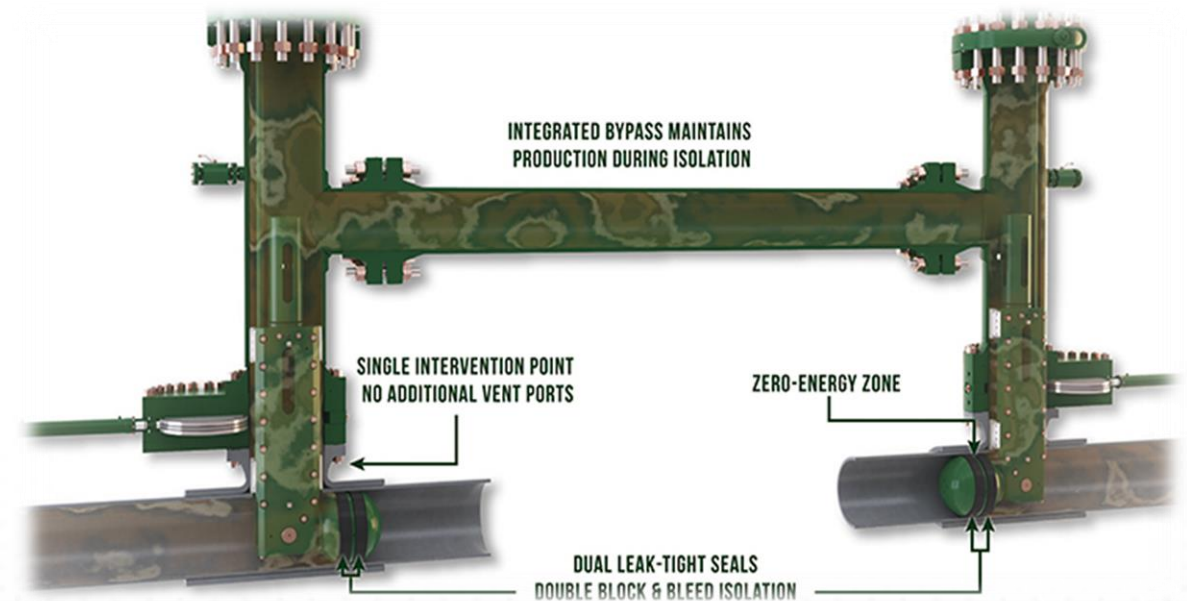

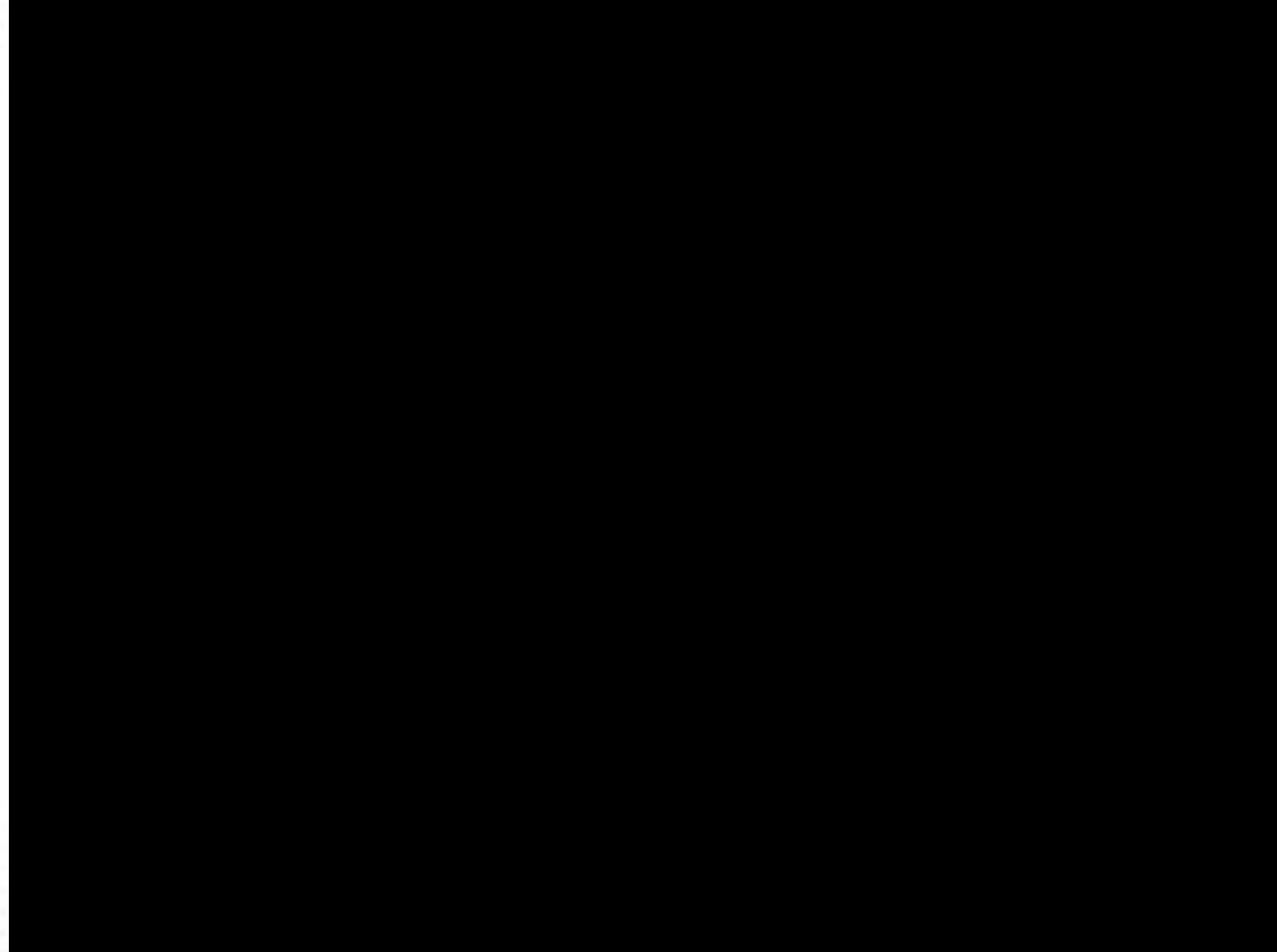



**Kinder Morgan – 30" 148barg Liquid CO2  
Bypass Maintaining Production**



**Kuwait Oil Company – 42" 30barg Gas Pipeline**

# Case Study – Largest BISEP and Hot Tap



**54" BISEP®, Abu Dhabi, UAE**



**54" SureTap®, Abu Dhabi, UAE**



**Thank You For Your Attention  
Questions?**

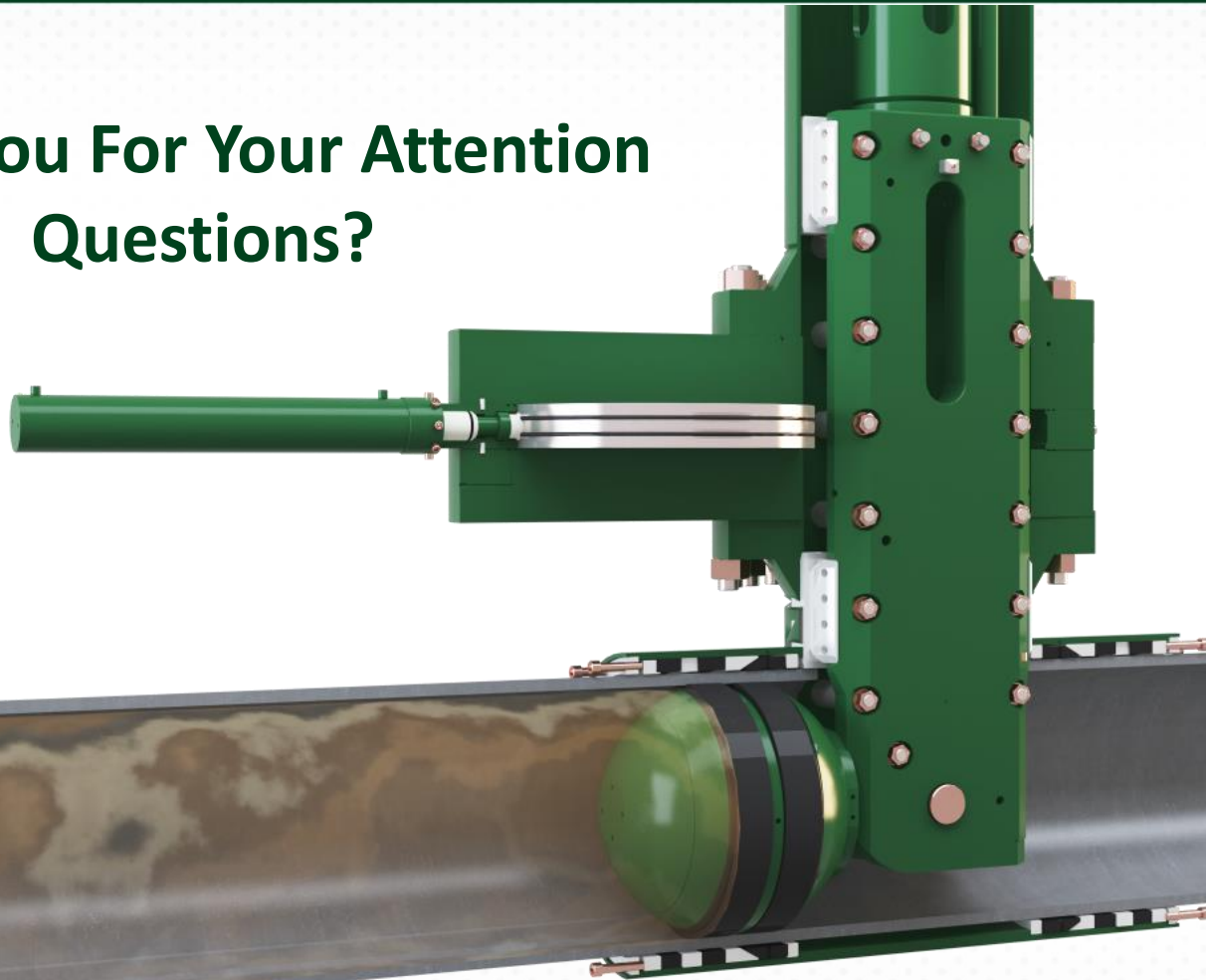

**for more information visit  
[www.statsgroup.com](http://www.statsgroup.com)**



# COPYRIGHT & DISCLAIMER



## Copyright

Copyright of all published material including photographs, drawings and images in this document remains vested in STATS (UK) Ltd and third party contributors as appropriate. Accordingly, neither the whole nor any part of this document shall be reproduced in any form nor used in any manner without express prior permission and applicable acknowledgements. No trademark, copyright or other notice shall be altered or removed from any reproduction.

## Disclaimer

Although STATS Group believes that the Presentation and the references therein are based upon reasonable assumptions, it can give no assurance that the actual results will be as set out in the Presentation. STATS Group is making no representation or warranty, expressed or implied, as to the accuracy, reliability or completeness of the Presentation or the data referenced therein, and neither STATS (UK) Ltd nor any of its directors, officers or employees will have any liability to you or any other persons resulting from your use.

STATS Group consists of many legally independent entities, constituting their own separate identities. STATS Group is used as the common brand or trade mark for most of these entities. In this presentation we may sometimes use “STATS”, “we” or “us” when we refer to STATS Group companies in general or where no useful purpose is served by identifying any particular STATS Group company.