

# ***GATOR*** ***PERFORATOR***

Presented By: Iain McHattie

# Techbyte: Gator Perforator

## GATOR ADVANTAGE

- The Deep Perforating Tool. (DPT)
- Hydromechanical – No Explosives.
- Can perforate two casing strings cemented at once.
- Repeatable.
- Depth of penetration can be controlled.

600-DPT Converted to 1200  
Cutting 13 3/8" Casing

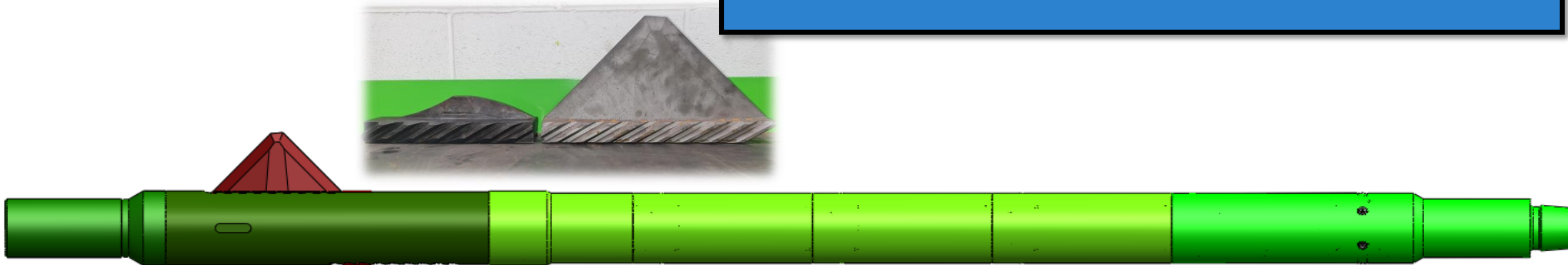

# Techbyte: Gator Perforator



# Technology Application Review #1

- Client Unable to verify isolation on outer string.
- 9 5/8" and 13 3/8" into formation.
- Perf and test would allow verification, by applying hydraulic pressure between two sets of perforations.
- Drill pipe turned ¼ turn after every perforation to orientate blade away from previous perforation.
- A Coretrax RTP Packer deployed between perforations, and communication was achieved between the two sets of perforations.

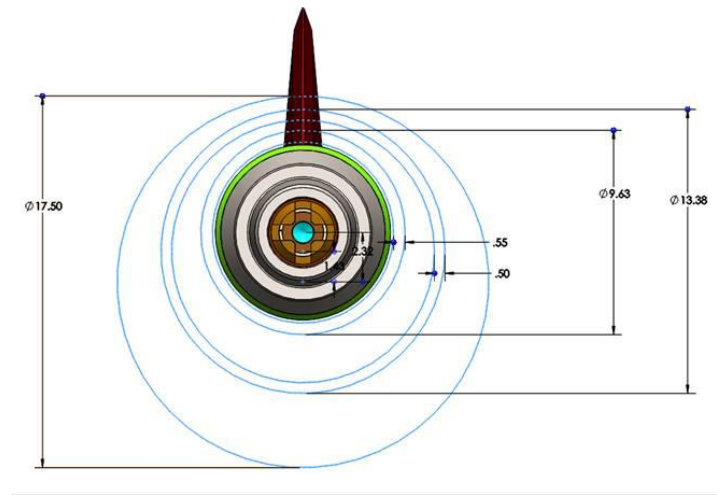
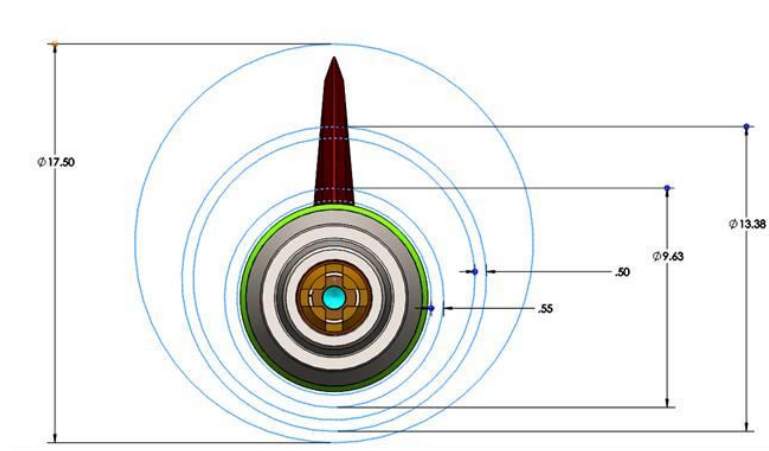
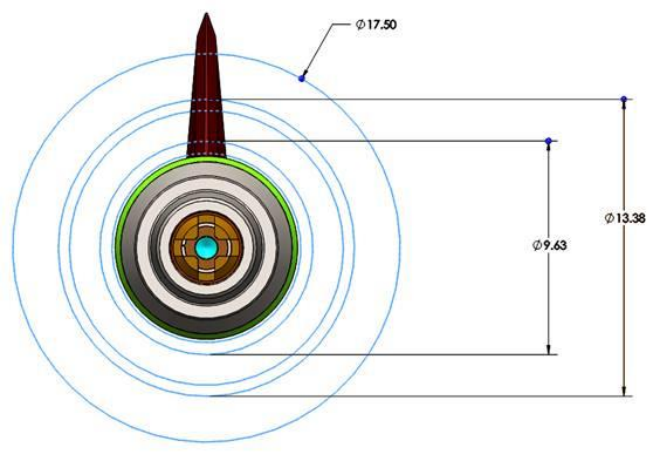
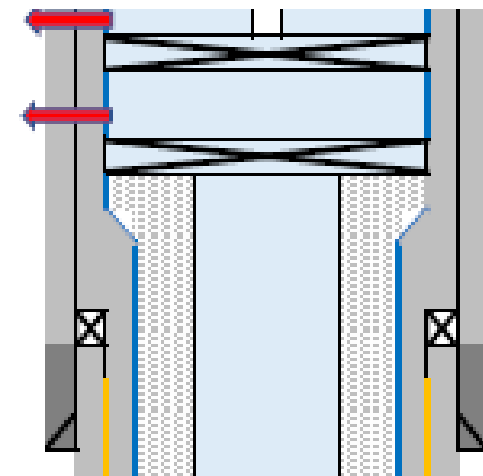
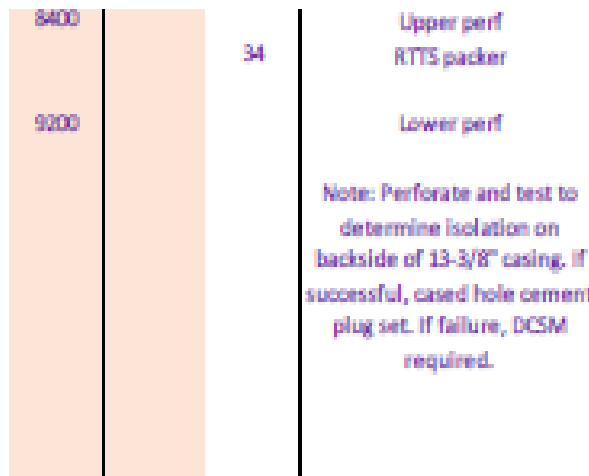

# Technology Application Review #2

- Environmental top plug for abandonment.
- Perforate 9 5/8" and 13 5/8" casing to circulate the C annulus of Oil based Mud at 500ft.
- Access to C-annulus from surface.
- 4 DPT perforations every 2ft.
- 16" casing not to be damaged.
- Circulation rates @ 5bpm at 280psi
- Total job time including circulating the annulus 4.5hrs.

Test cut done prior to load out

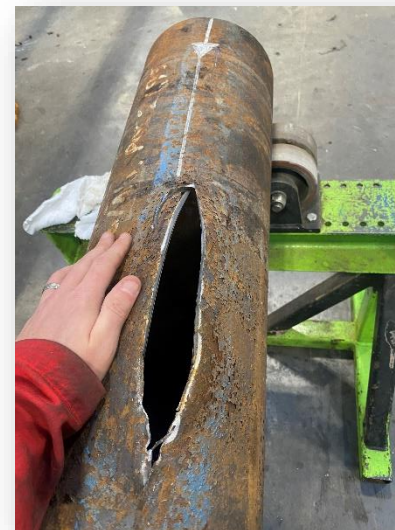

9 5/8" Perforation



13 3/8" Perforation

# Technology Application Review #3

- 10 ¾" 110# P110 1.06" wall thickness – Perforated at 2000psi.

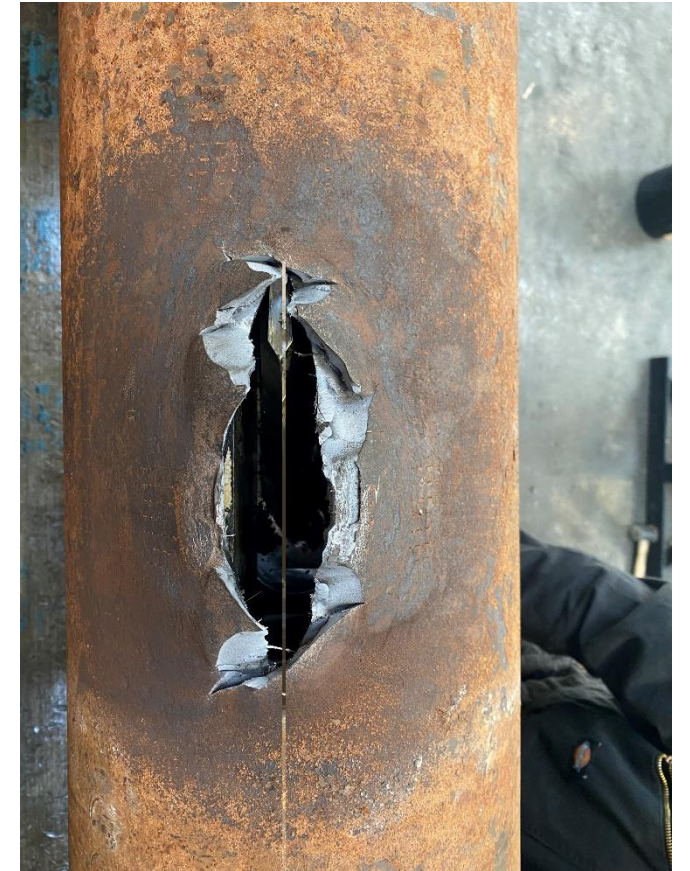
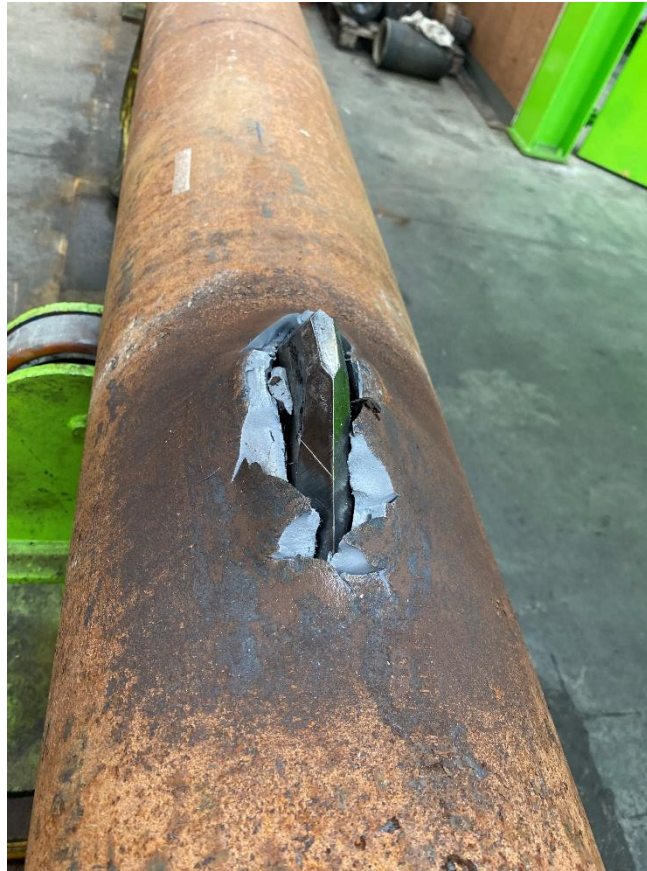

Thank You!

**GATOR**   
**PERFORATOR**